

Supplemental Information & Instructions for 282-308 Bushing Set, Adjustable Camber Austin Healey 100, 100-6, 3000, MGB, MGC, Sprite-Midget

Contents of Kit

Fig 1



The camber is preset on many British Sports Cars, and there is no provision for any adjustment. In some cases, you will find that the camber is not correct due to collision damage, and even though the damage has been repaired, the camber is off. In other cases, dialing in a suspension with new wheels & tires may make it necessary to change the camber from a stock setting. Dealing with either situation is very difficult using the stock suspension components. Moss is therefore pleased to offer these bushings, which make it possible to adjust the camber on a variety of cars. These bushings were originally developed for use on Austin Healeys by Eric Grunden of "Absolutely British". Eric is well known in Healey circles for his work restoring and repairing Healeys.

What is Camber?

Camber is the angle of the wheel relative to vertical, as viewed from the front or the rear of the car. If the top of the wheel leans in towards the chassis, it has negative camber; if the top of the wheel leans away from the chassis, it has positive camber.

The cornering force that a tire can develop is highly dependent on its angle relative to the road surface, and so wheel camber has a major effect on the road holding of a car. It's interesting to note that many specialists feel that a modern radial tire develops its maximum cornering force at a small negative camber angle, typically around neg. 1/2 degree. "This fact is due to the contribution of camber thrust, which is an additional lateral force generated by elastic deformation as the tread rubber pulls through the tire/road interface (the contact patch)."

Although the camber of a tire while cornering is what matters, it cannot be measured easily except at rest, and so camber is set to the manufacturer's specifications with the car sitting still. You can tell if you have positive or negative camber by measuring the distance from a plumb line suspended from the fender lip to the top and bottom edge of the rim. If the top of the rim is farther away from the plumb line than the bottom of the rim, you have negative camber. If it is the opposite, you have positive camber. Since camber is measured in degrees, you will be hard pressed to tell exactly what your camber is—that is a job for the alignment shop. The point is, you can set the camber roughly in your garage and have the camber be fairly close on both sides.

Have it checked by the alignment shop and you can fine tune it if necessary.

So How do these Bushings Work?

Look at the figures to the right.

On the MGB, MGC, and Austin Healey, there is LESS camber with the bushings rotated to put the hole closest to the engine.

On the Sprite-Midget, there is MORE camber with the bushings rotated to put the hole closest to the engine because the bushings are in the lower control arm.

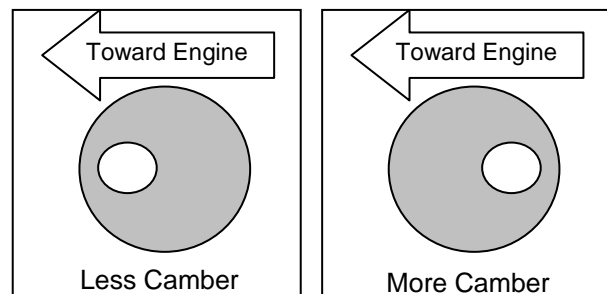

50 **Instructions, Austin Healey 100-4, 100-6, 3000**

51
52
53
54
55
56
57
58
59
60
61
62
63
64
65
66
67
68
69
70
71
72
73
74
75
76
77
78
79
80
81
82
83
84
85
86
87
88
89
90
91
92
93
94
95
96
97
98
99
100
101
102
103
104

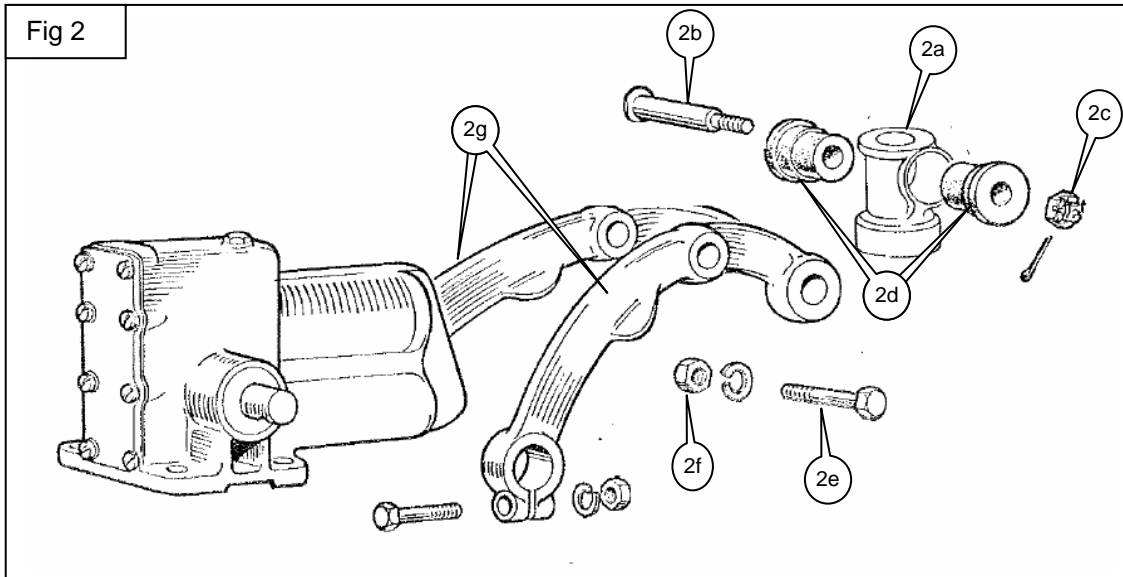

71 *Factory specifications call for 1° positive camber for all models. With modern tires, many shops suggest*
72 *0°, and for higher performance driving, 0.5° negative. The actual best camber angle for your combination*
73 *of car, tires, and driving habits will have to be determined by testing. If you don't want to go through that,*
74 *we suggest you set the camber to 0°. Please note: These tips do not replace the factory workshop*
75 *manual. Read sections L5 and L6 before you start.*

77 Jack the front end up and support the frame on suitable jack stands.

78 Remove the front road wheels.

79 Start on one side.

80 Jack up spring pan to take the tension off the upper trunnion (2a).

81 Remove the cotter pin and the castle nut (2c) from the upper fulcrum pin (2b).

82 Loosen the pinch bolt /nut (2e, 2f) that hold the shock arms (2g) together.

83 Drive the pin (2b) out of the upper trunnion.

84 Use a pry bar to lever the trunnion (2a) out from between the ends of the shock arms.

85 Remove the old bushings (2d).

86 Insert a new bushing in one side of the trunnion.

87 Insert the pin through the first bushing so it protrudes through the other side of the trunnion.

88 Place the second bushing onto the pin and press it home in the trunnion.

89 *The pin acst to align the holes on the bushings, which means you will be able to install the pin later.*

90 Remove the pin, taking care not to disturb the bushings.

91 Use a pry bar to separate the shock arms slightly – you will need the room.

92 Push the trunnion back into place between the ends of the shock arms.

93 Press shock arms back together, tightening the pinch bolt that holds the arm together.

94 Refit the fulcrum pin. **Do not tighten the nut yet.**

95 Set the suspension to the normal ride height by placing a 2 inch thick spacer (wooden block) on top of the
96 upper spring plate, under the upper shock/wishbone arms.

97 Tighten the nuts on the fulcrum pins and replace the split pins.

98 Remove the 2" spacer block.

99 Repeat on the other hand side.

100 Replace the roads wheels and remove the jack stands.

101 Bounce the vehicle on the springs to settle it.

102 Roll the car backwards, then forwards 15' on smooth, level ground.

103 Check your camber using the plumb line and rule as described earlier- it should be the same on both
104 sides.

105 **Instructions, MGB**

106
107 Fig 3

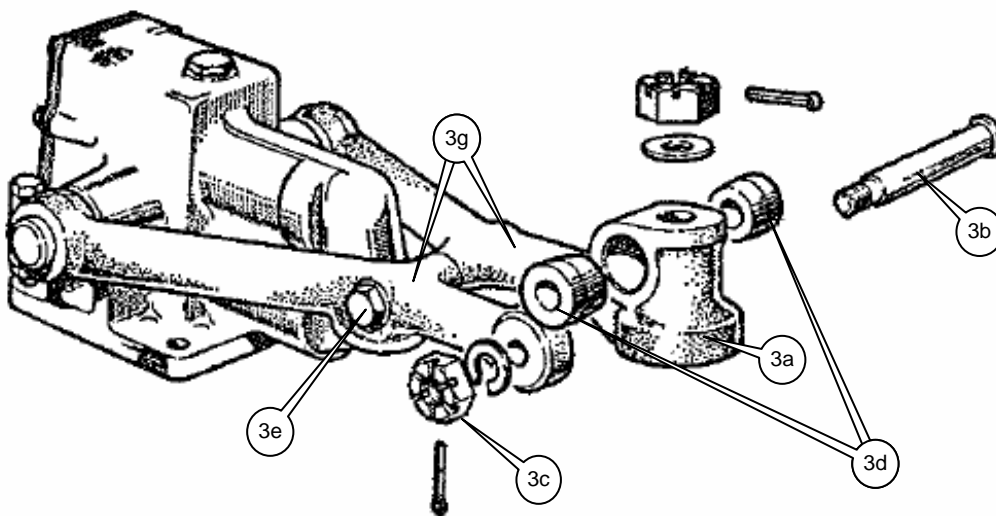

128 *Factory specifications call for 1° positive camber (+1/4, -1 ¼). With modern tires, many shops suggest 0°,*
129 *and for higher performance driving, 0.5° negative. The actual best camber angle for your combination of*
130 *car, tires, and driving habits will have to be determined by testing. Please note: These tips do not replace*
131 *the factory workshop manual. Read section K before you start.*

133 Jack the front end up and support the frame on suitable jack stands.

134 Remove the front road wheels.

135 Start on one side.

136 Jack up spring pan to take the tension off the upper trunnion (3a).

137 Remove the cotter pin and the castle nut (3c) from the upper fulcrum pin (3b).

138 Loosen the pinch bolt /nut (3e) that hold the shock arms (3g) together.

139 Drive the pin (3b) out of the upper trunnion.

140 Use a pry bar to lever the trunnion (3a) out from between the ends of the shock arms.

141 Remove the old bushings (3d).

142 Insert a new bushing in one side of the trunnion.

143 Insert the pin (3b) through the first bushing so it protrudes through the other side of the trunnion.

144 Place the second bushing onto the pin and press it home in the trunnion.

145 *The pin acts to align the holes on the bushings, which means you will be able to install the pin later.*

146 Remove the pin, taking care not to disturb the bushings.

147 Use a pry bar to separate the shock arms slightly – you will need the room.

148 Push the trunnion back into place between the ends of the shock arms.

149 Press shock arms back together, tightening the pinch bolt that holds the arm together.

150 Refit the fulcrum pin. **Do not tighten the nut yet.**

151 Repeat on the other side.

152 Replace the roads wheels and remove the jack stands.

153 Bounce the vehicle on the springs to settle it.

154 Now tighten the nuts on the fulcrum pins and replace the split pins.

155 Roll the car backwards, then forwards 15' on smooth, level ground.

156 Check your camber using the plumb line and rule as described earlier- it should be the same on both
157 sides.

158
159

160 **Instructions, MGC**

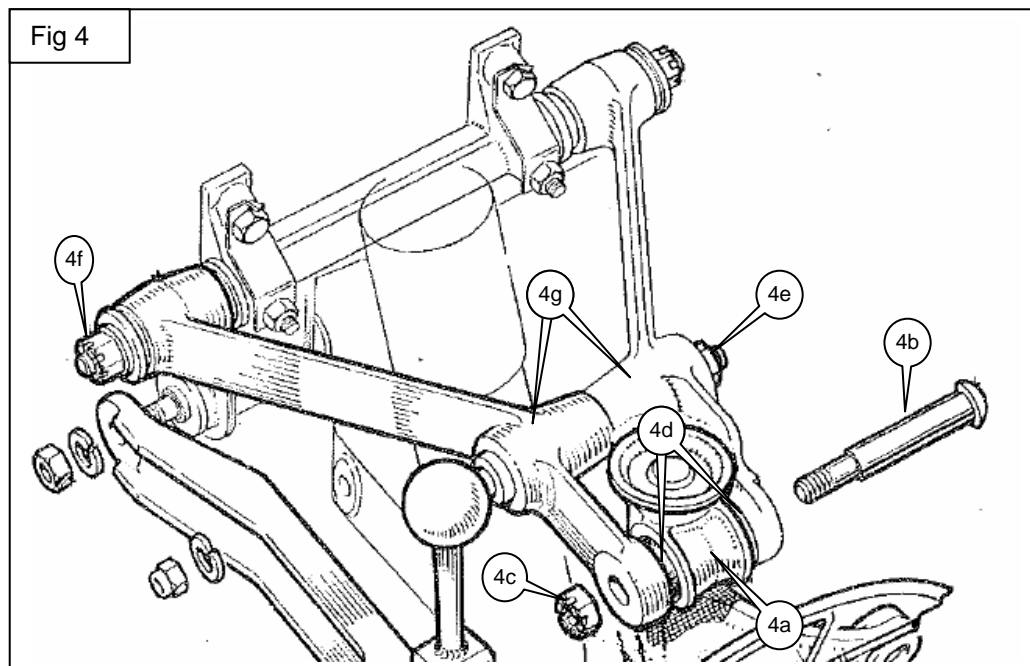

183 *Factory specifications call for 1° positive camber (+15', -1 ¼'). With modern tires, many shops suggest 0°,*
184 *and for higher performance driving, 0.5° negative. The actual best camber angle for your combination of*
185 *car, tires, and driving habits will have to be determined by testing. Please note: These tips do not replace*
186 *the factory workshop manual. Read section 10.B before you start.*

187

188 Jack the front end up and support the frame on suitable jack stands.

189 Remove the front road wheels.

190 Start on one side.

191 Jack up spring pan to take the tension off the upper trunnion (4a).

192 Loosen the anti-roll bar link nut (4e) (this holds the upper arms (4g) together.)

193 Remove the split pin and loosen the nut securing the front half of the upper arm.

194 Remove the cotter pin and the castle nut (4c) from the upper fulcrum pin (4b).

195 Move the front half of the upper arm forward slightly.

196 Drive the pin (4b) out of the upper trunnion.

197 Use a pry bar to lever the trunnion (4a) out from between the ends of the upper arms.

198 Remove the old bushings (4d).

199 Insert a new bushing in one side of the trunnion.

200 Insert the pin (4b) through the first bushing so it protrudes through the other side of the trunnion.

201 Place the second bushing onto the pin and press it home in the trunnion.

202 *The pin acts to align the holes on the bushings, which means you will be able to install the pin later.*

203 Remove the pin, taking care not to disturb the bushings.

204 Push the trunnion back into place between the ends of the upper arms.

205 Press front half of the upper arm back into place, tightening the anti-roll bar link nut (4e) that holds the
206 arms together.

207 Refit the fulcrum pin. **Do not tighten the nut yet.**

208 Repeat on the other side.

209 Replace the roads wheels and remove the jack stands.

210 Bounce the vehicle on the springs to settle it.

211 Now tighten the nuts on the fulcrum pins and replace the split pins.

212 Roll the car backwards, then forwards 15' on smooth, level ground.

213 Check your camber using the plumb line and rule as described earlier- it should be the same on both
214 sides.

215 **Instructions, Sprite-Midget**

216
217
218
219
220
221
222
223
224
225
226
227
228
229
230
231
232
233
234
235
236
237
238
239
240
241
242
243
244
245
246
247

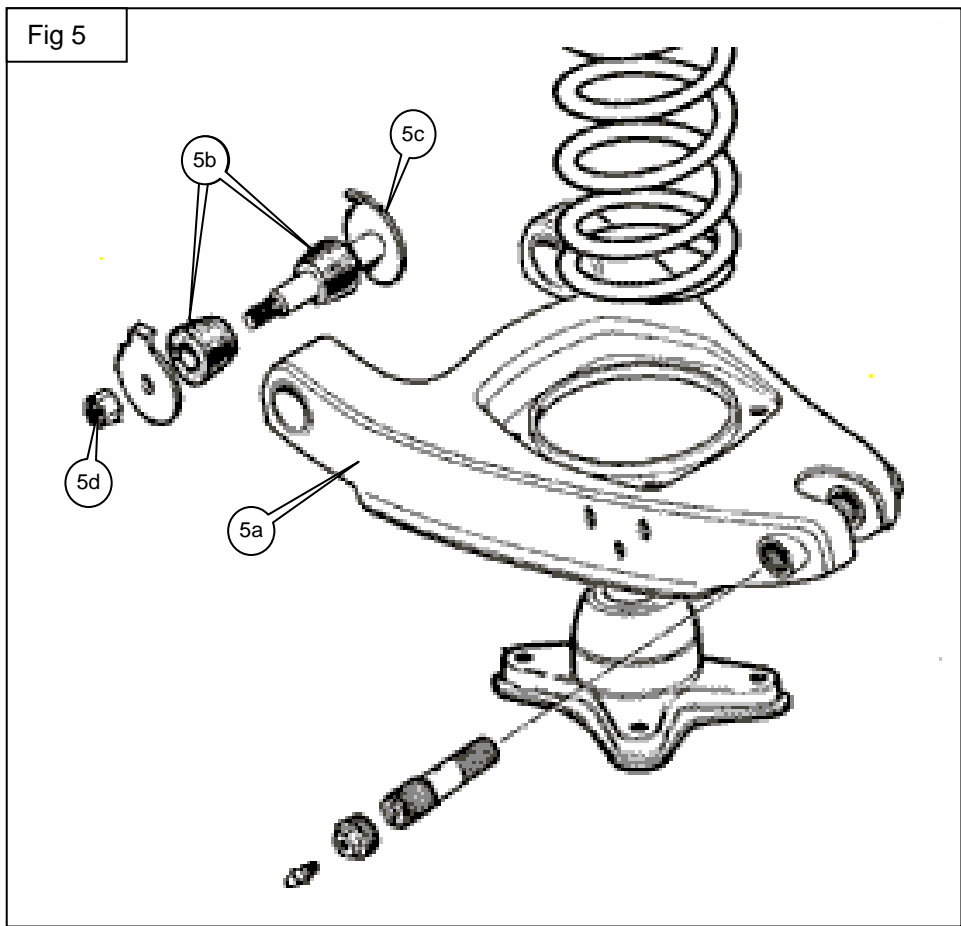

248 *Unlike the other applications for these bushings, the Sprite Midget can be fitted with the adjustable*
249 *camber bushings at the inner ends of the lower arms. The stock bushings (5b) will be replaced. Because*
250 *the Sprite-Midget uses four bushings per side, and the 282-308 is a set of four, you will need two of the*
251 *282-308 kits to do the vehicle.*

252
253 *Follow the instructions in the factory workshop manual for replacing the bushings. We will add more*
254 *detailed instructions as information becomes available.*

255
256
257 *Although every effort has been made to ensure the accuracy and clarity of this information, errors and/or*
258 *omissions on our part are almost inevitable. Any suggestions that you may have that will improve the*
259 *information (especially detailed installation notes) are welcome. Please use the simple email form on the*
“Contact Us” page on the Moss website: <http://www.mossmotors.com/AboutMoss/ContactUs.aspx>
If you prefer, you may call our Technical Services Department at 805-681-3411. So many people call us for
help that we are often not able to answer the calls as fast as we’d like, and you may be asked to leave a
message. We apologize in advance for the inconvenience. We will get back to you within 2 business days.



Moss Motors, Ltd.

440 Rutherford Street, Goleta, California 93117
In the US & Canada Toll Free (800) 667-7872 FAX (805) 692-2510 (805) 681-3400

Moss Europe Ltd.

Hampton Farm Industrial Estate, Hampton Road West, Hanworth Middlesex, TW13 6DB
In the UK: 020-8867-2020 FAX:- 020-8867-2030