

Supplemental Information for 021-511 or 120694 Angle Drive (Speedometer Cable to Gearbox) Austin Healey BN4-BJ8, MGB 63 on, TR'S 63 on



This speedometer angle drive was fitted to many British cars where there was insufficient room to run the speedometer cable directly into the gearbox. The original angle drives quickly developed a reputation for being prone to failure. This resulted in a thorough investigation that in the end resulted in the Technical Service Bulletin (TSB) of February 29, 1968. The TSB (copy on the next page) explains that the 324-720 or 3H550 "washer-adaptor to gearbox" **must** be fitted with the angle drive. If the washer is left out, the end load on the angle drive will be excessive and it will fail. When we first offered our reproduction of the 120694 angle drive, we included information in the catalog and with the part regarding the necessity for the washer.

We also assumed (incorrectly, as it turned out) that the angle drive being replaced would probably have the necessary washer, which could be transferred to the new angle drive. Despite our best efforts to get the word out, a significant number of new angle drives were fitted without the washer. It became apparent that the best thing to do would be to simply include the 324-720 or 3H550 washer with the angle drive, and explain why it was needed.

IMPORTANT! When fitting the angle drive, fit a 324-720 or 3H550 washer as shown on the next page.



Moss Motors, Ltd.

440 Rutherford Street, Goleta, California 93117
In the US & Canada Toll Free (800) 667-7872 FAX (805) 692-2510 (805) 681-3400

Moss Europe Ltd.

Hampton Farm Industrial Estate, Hampton Road West, Hanworth Middlesex, TW13 6DB
In the UK: 020-8867-2020 FAX:- 020-8867-2030



TECHNICAL SERVICE BULLETIN

British Motor Holdings (U.S.A.) Inc.

734 GRAND AVENUE, RIDGEFIELD, NEW JERSEY 07657

February 29, 1968

TO ALL DISTRIBUTORS AND DEALERS

Re: Right Angled Speedometer Adaptor Failures

Repeated failures of the above have, in many instances, been caused by Washer-Adaptor to gearbox Part Number 3H 550 not being fitted when a new right angled drive adaptor is installed.

This causes an excessive end load and premature failure of the right angled drive pinion.

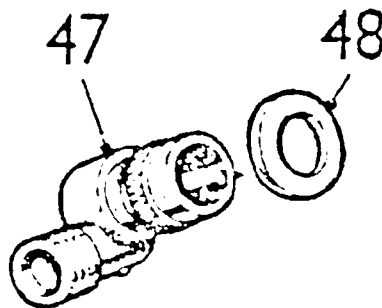

WASHER 3H 550