

# FRONTLINE Developments

## FRONT SUSPENSION FITTING INSTRUCTIONS

Please read all the instructions before starting any work.

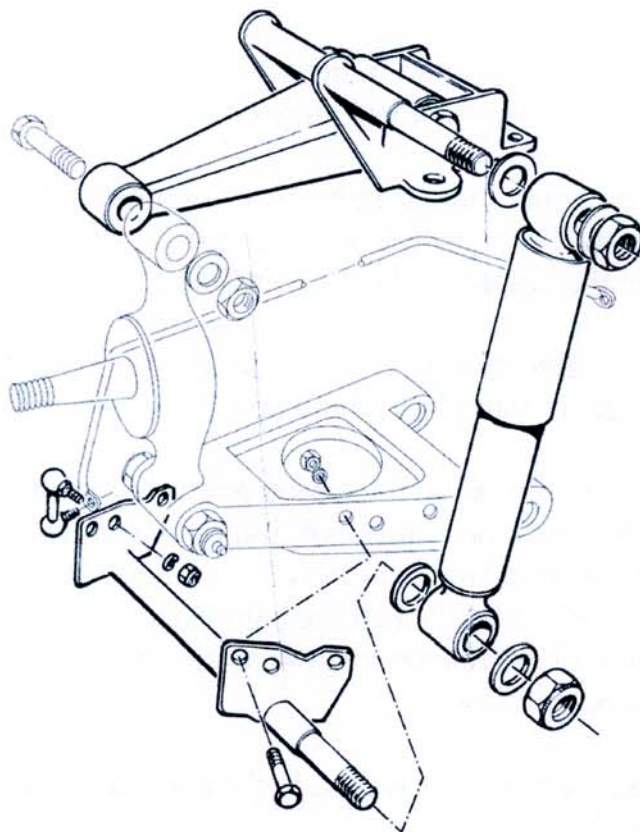

**ONCE FITTED YOUR NEW SUSPENSION SET UP SHOULD LOOK LIKE THE ONE ABOVE, WITH THE SHOCK ABSORBERS MOUNTED TOWARDS THE REAR OF THE CAR.**

1. Follow the workshop manual instructions for removing the old lever arm shock absorber, ensuring that the car and suspension are supported correctly. Take special care with the coil springs which can be dangerous if mishandled.
2. The new suspension arms have four mounting bolt holes for extra support. To fit, bolt the new arm to the three existing bolt holes then drill through the fourth and use the supplied nut and bolt for this hole. The body of the new top link should be square with the base plate on which it is mounted.

**Note:** On some models the brake pipe is mounted under the suspension arm instead of through the inner wing. If this is the case with your car you will need to move the pipe. To do this drill through the inner wing close to the suspension arm but not in a position that will foul the new shock absorber. If you have access to an MG Midget with this type of brake pipe fixing it may be advisable to look at the correct position.

*continued*

3. Refit the king pin to the top arm in the usual manner. (We do not advise the use of nylatron suspension bushes except for race purposes because the new top link has already taken up a great deal of play in the suspension. Nylatron bushes may then feel a little too harsh and the road noise would be transmitted straight through to the body of the car.)

**Note:** When fitting any metal to metal components, it is advisable to use copper grease or similar to make any future work easier.

Before tightening the king pin top bolt you should support the suspension arm with a jack to the point that the car's weight is supported on the suspension. This brings the suspension into a working position to tighten the bolt and prevents excessive load on the suspension rubbers making them last longer.

4. Bolt the lower shock absorber mounting bracket into place. This bolts onto both sides of the wishbone using the holes drilled for the anti-roll bar mounting plates. The anti-roll bar still mounts in the normal fashion. New bolts are supplied for this.

**Note:** When fitting in conjunction with reproduction wishbone pans, you may need to push the new lower bracket into place as the new pans are slightly narrower.

5. Place the shock absorber onto the two location points and turn the steering to full lock. This is to check that the brake pipe does not foul on the shock absorber. We have found some irregularities in the angle at which the banjo fixing is positioned on the brake caliper. If this is the case, slacken the banjo nut, reposition the banjo until the brake pipe does not foul the shock absorber then tighten the banjo nut. You will then need to bleed the brakes.
6. If you do not have this problem or have made the necessary alterations, you can now bolt on the shock absorber using the large stainless steel washers and M12 bolts.

**Note:** The shock absorber mounting bolts are shouldered to the correct length to prevent over tightening. Please do not attempt to alter this.

7. Having done all of this, ensure that all the nuts are tight and locking devices are in place.

### **Wheel alignment**

8. Having changed the top arm, the tracking will have altered so it must be reset but not to the original setting. The tracking must now be set to approximately 1/16" (1-2mm) toe in. It is vital that there is no toe out as this will cause the car to wander around.
9. Having done all this make your final checks and you should be ready to try it.

Take a little time to get used to it as it will be a new sensation.

**HAVE FUN!**